



AUDIO FOR THE **NEXT** GENERATION



## **AC Series 1 Channel Amplifiers**

Compact Class D Mono Amplifier Series

Models: AC500.1D, AC1000.1D, AC1500.1D

## **Installation and Operation Manual**

Please take time to thoroughly read through this manual to familiarize yourself with your new amplifier.  
This will ensure that your amplifier will perform at its optimum capabilities.

Para obtener una copia de este manual en español, visite [www.aunexusa.com](http://www.aunexusa.com) y luego vaya a la página del producto que necesita. Haga clic en la pestaña Soporte y descargue su manual en español.



Congratulations and thank you for purchasing an Aunex AC Series Amplifier. This product has been engineered and manufactured utilizing precision quality parts and craftsmanship. Improvements in sound quality and system performance will be greatly enhanced with the use of this amplifier.

To ensure maximum performance we highly recommend you have your new Aunex product installed by an Authorized Aunex Dealer. Should you decide to install this product yourself, please make sure to read this manual thoroughly to familiarize yourself with the necessary installation requirements and tuning procedures.

Please read your warranty and retain a copy of your purchase receipt and original carton should your Amplifier ever needs to be serviced and warranted.

Visit our website for the latest information on all Aunex products at: [www.aunexusa.com](http://www.aunexusa.com). If you have any questions regarding this product, please contact your Authorized Aunex Dealer for assistance or call / email Aunex Technical Support Department at (909) 589-5010 / [tech@aunexusa.com](mailto:tech@ aunexusa.com).

**Caution: Continuous exposure to sound pressure levels over 100dB may cause permanent hearing loss. High powered audio systems can produce sound pressure levels that can exceed over 150dB. Please limit your exposure to continuous high listening volumes.**



## Feature Set of the AC Series Mono Amplifiers

- Heavy Density Aluminum Extruded Heatsink
- 4 Layer PCB, SMD Technology
- Conformal Coated PCB
- Differential Balanced RCA Inputs
- Output Clipping Indicators
- Fully Variable Crossover 24dB/Octave
- Boost Eq. 0 – 18dB @ 45Hz Center
- Fully Variable Infrasonic Filter 10Hz – 50Hz @ 24dB/Octave
- Autosensing in High Level Input Mode
  - Remote Input Becomes Remote Output Trigger if High level Input is used.
- Power and Protection Logo Illuminated Status Indicator
  - Blue Indicates Amplifier is powered On.
  - Red Indicates the Amplifier is in Protection
- Blue Illuminated Power Input and Speaker Output Terminals
- 4 Gauge Power & Ground Terminals
- 8 Gauge Speaker Output Terminals
- Advance Protection Circuit Monitoring: Short, Thermal, Overload and Impedance
- Remote Level Controller
- Finish: Anodized with Texture Paint

## What's Included

- (1) AC Series Mono Class D Amplifier
- (1) Remote Level Controller, Cable and Wing Adapter
- (1) In-Line Fuse Holder with Mini ANL Fuse
  - AC500.1D is supplied with 2 x 30A Fuses
  - AC1000.1D is supplied with 3 x 30A Fuses
  - AC1500.1D is supplied with a 200A Fuse
- (6) Self Tapping Screws; (4) for Amplifier, (2) for Remote
- (2) Allen Wrenches
- (1) Instruction Manual
- (1) Sticker

## **Important Safety Considerations**

- To prevent personal injury and damage to the unit, please read the following instructions in this manual.
- This product is designed to use in vehicles with 12Volt, negative-ground electrical systems.
- Install this product in a dry location away from your vehicles' safety equipment (airbags, seat belt system, etc.). Water and humidity may damage internal components.
- Use the included mounting accessories to secure this product so that it does not come loose.
- Check before drilling to make sure you do not drill into any vital vehicle system.
- Protect all system wiring from sharp metal edges.
- Do not disassemble or modify this unit; doing so will void your manufacturer's warranty.

## **Important Installation Precautions**

Installation of mobile audio equipment requires experience. Although this manual provides general installation procedures, it will not show the exact installation method for your particular vehicle.

If you do not have the required knowledge and experience, we recommend that you have your equipment installed by an Authorized Aunex Dealer.

- Turn off all stereo and other electrical devices before you begin.
- Disconnect the negative (-) lead from your vehicle's battery to avoid an electrical short. Reconnect the negative lead to your battery once your installation is complete. So, in other words the negative lead from our vehicle's battery is the first connection you remove before starting your installation and the last connect you make after you finish your installation.
- Check your mounting location to make sure there is sufficient room for your installation placement preference.

## **Important Installation Precautions Continued**

- Install this product in a dry location away from your vehicles' safety equipment. Each AC Series amplifier circuit board has been coated with a protective layer of Conformal Coating. This will help protect the electronic circuit from harsh environments that may contain humidity and a range of airborne contaminants and varying temperatures. However prolonged exposure to water and high humidity may damage internal components in time. Keeping the amplifier dry and installed in a well-ventilated area will help ensure many years of listening enjoyment.
- When running power cables through sheet metal it is best to use grommets and loom to properly insulate your cables from metal edges.
- Avoid mounting the amplifier with the top fins facing down as this may increase the operating temperature of your amplifier.
- If mounting underneath a seat, make sure that there is at least 1 inch (25mm) of space above the amplifier to permit proper cooling.
- Avoid mounting the amplifiers on a subwoofer enclosure as prolonged excessive vibration may damage your amplifier.

## **Mounting Placement**

Choose a structurally sound location to mount your Aunex amplifier, making sure there are no items behind the area where the screws will be driven.

For optimum sound quality, it is highly recommended that you purchase Aunex wiring accessories as they are designed to give your amplifiers high-quality signal it needs to operate at peak performance levels. Aunex provides a wide selection from RCA cables and power wire to speaker wire and battery connectors.

## Side Panel Layout

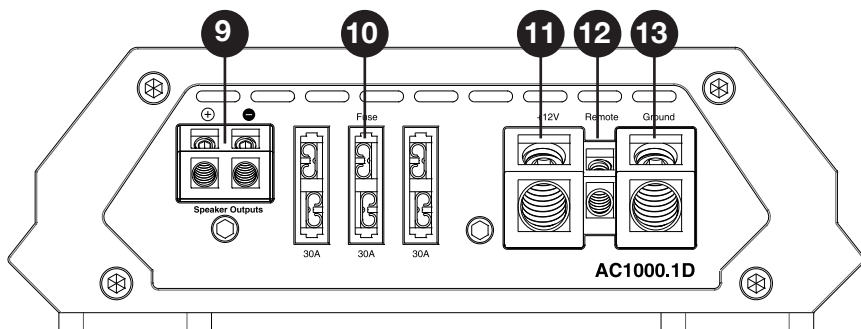
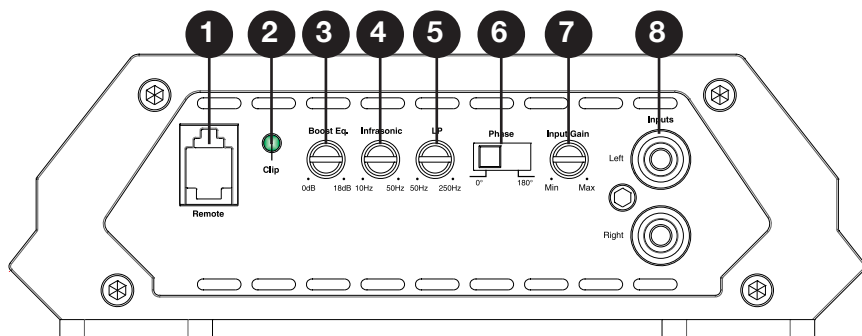

## Side Panel Layout Continued

- 1. Remote Level Control:** With the Remote Level Control plugged to your amplifier, you can now adjust the amount of output from the convenience of this controller. There are several mounting options for your controller. With the supplied wing attachment, you can mount the controller under your dash. Should you want to mount the controller flush to your dash, arm rest or any other panel of your vehicle the wing attachment will more than likely not be needed.

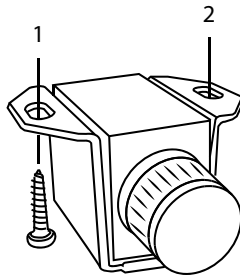

- 2. Clipping Led Indicators:** These LED's will light up when the amplifier output signal is being clipped. When the LED's starts to glow, your amplifier output is between 1-2% THD (Total Harmonic Distortion). When the clipping indicators are fully lit, your amplifier output is between 6-7% THD (Total Harmonic Distortion). The ideal gain setting is where the clip indicators are not lit allowing the amplifier to send undistorted clean output. Setting the amplifiers gains improperly where the clip indicators are always lit will over-work the amplifier and may cause excessive heat building and possibly product failure.
- 3. Boost Eq:** Your AC Series amplifiers incorporates a Boost Eq. circuit that can increase output 0-18dB centered at 45Hz. Note if you turn up the Boost Eq, you will need to readjust the Input Gains to avoid clipping the output signal. Using the Clipping LED's will help set your Boost Eq and Input Gains properly.

## Side Panel Layout Continued

- 4. Infrasonic Filter:** This variable potentiometer will provide a roll off point for lower frequencies (10Hz – 50Hz variable) that could potentially damage your subwoofers from over-excursion. The frequency setting for your Infrasonic Filter is to be set relative to your subwoofers low-frequency capabilities along with enclosure tuning. In a sealed box Aunex recommends setting the Infrasonic Filter between 25Hz – 35Hz. In a ported enclosure Aunex recommends setting the Infrasonic filter at  $\frac{1}{2}$  an Octave below your tuned frequency.

For example, let say your ported enclosure is tuned at 40Hz. Take  $\frac{1}{2}$  of 40Hz which is 20Hz (this is one octave lower). Now take another half off 20Hz which is then 10Hz (this is half an octave lower). Now take 10Hz from 40Hz which is 30Hz and where you should set your Infrasonic Filter.

- 5. Low Pass (LP) Filter Frequency Filter:** This potentiometer allow you to adjust the crossover frequency from 50Hz – 250Hz.
- 6. Phase Switch:** Depending on the absolute phase of your main speakers and amplifier and the distances of the subwoofers and the main speakers from the main listening position, the bass in the crossover region maybe smoother if you reverse the subwoofer's phase. Try both settings to determine which polarity produces the best overall bass performance in your system. Typically though, phase is left at the 0° for most installation.
- 7. Input Gain:** Use this Input Gain Potentiometer to match the output voltage of your headunit / source unit to the input circuit of your amplifier. **This Input Gain is not a volume knob.** A simple method of setting your Input Gain is to turn your headunit / source unit up to approximately  $\frac{3}{4}$  volume. Then slowly adjust your Input Gain on your amplifiers clockwise until you can hear distortion from your subwoofer(s). Then turn the gains down (counterclockwise) till the distortion is no longer heard and your clipping indicators are not lit.





## Side Panel Layout Continued

- 8. Low Level RCA Inputs:** These are your differential balanced inputs that are used to connect audio signal from your headunit / source unit to your amplifier. Your AC Series Amplifier is capable to receiving either High Level Speaker Outputs or Low-Level RCA cables. If you are using High Level Speaker outputs, you may need a high to low level adapter such as the Aunex AP-SL2 adapter.
- 9. Speaker Outputs:** Your AC amplifier speaker outputs are designed to accept 16 AWG to 8 AWG wire. Turn the set screws on this terminal counterclockwise to loosen the screws using the supplied Hex wrench. Strip the PVC jacket from your speaker wire ½ inch (12mm). Then insert the bare wire into the terminal block so that no bare speaker wire is exposed. Then tighten the set screw by turning it clockwise.

**Loading your amplifier below the recommended impedance rating found on page 13 is not recommended and may cause your amplifier to enter into protection mode and may void your warranty.**

For maximum current flow, Aunex recommends that you tin your speaker wire before connecting it to the speaker output terminals. In addition, Aunex recommends using high quality 100% OFC (Oxygen Free Cooper) or Tinned 100% OFC speaker wire. This will ensure that your speaker / subwoofer receives maximum output from your amplifier.

- 10. Fuse Holder:** This is your fuse block. The AC500.1D and the AC1000.1D has fuses mounted on the side panel. The AC1500.1D includes an external fuse holder. Should there be a short in your system or if your amplifier is being overdriven, these fuse(s) will typically burn to prevent damage to your amplifier. If it is required to replace your fuse(s), use the same fuse rating that comes with your amplifier. Using a higher fuse may damage your amplifier and will void your warranty.

## Side Panel Layout Continued

**11. +12Volt Positive Terminal:** The +12Volt positive terminal is designed to accept up to 4 AWG wire. Use the supplied fuse block and make your +12Volt connection directly to the positive battery post. The Fuse should be installed within 18" (457mm) of the battery. This fuse is vital to protecting the vehicle and amplifier from a dead short. Turn the set screws on this terminal counterclockwise to loosen the screw using the supplied Hex wrench. Strip the PVC jacket from your speaker wire ½ inch (12mm). Then insert the bare wire into the terminal block so that no bare power wire is exposed. Then tighten the set screw by turning it clockwise.

For maximum current flow, Aunex recommends that you tin your power wire before connecting it to the +12Volt terminal. In addition, Aunex recommends using high quality 100% OFC (Oxygen Free Cooper) or Tinned 100% OFC speaker wire. This will ensure that your speaker / subwoofer receives maximum output from your amplifier.

**12. Remote Input Terminal:** This terminal must be connected to a switched +12Volt source. If the source unit does not have a remote Turn on lead, then a switched +12 supply should be used such as the ACC +12Volt. Run an 18-gauge wire from the Remote Turn-On Lead from your headunit / source unit to this terminal.

**If you are using the High-Level Speaker Outputs connection to the amplifiers' RCA inputs, you do not need to connect a remote input to your amplifier. Your amplifier will automatically detect the speaker signal and will turn on your amplifier via its DC Offset circuit. In addition, the remote input terminal then becomes a remote output trigger which can be used to turn on another amplifier or processor that requires a +12volt remote connection.**

## Side Panel Layout Continued

- 13. Ground:** The Ground terminal is designed to accept up to 4 AWG wire. Make your ground connection directly to the chassis of the vehicle as close to the amplifier as possible. Make sure this connection is made with the same gauge wire as used for your +12Volt connection. Ensure that all dirt, grease and paint is removed from your chassis ground point prior to attaching the ground wire. **Aunex recommends when making your chassis ground to use a Star Washer which will help prevent your ground bolt from loosening.**

### Power Connection

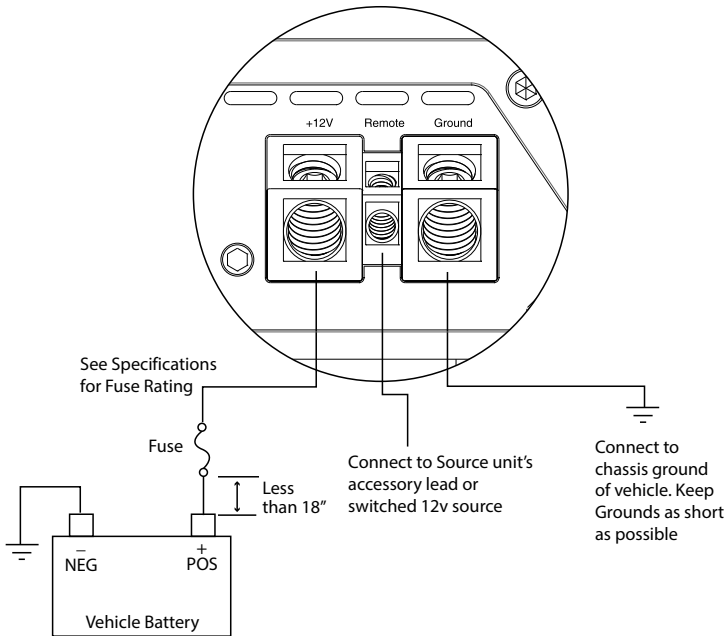

For maximum current flow, Aunex recommends that you tin your ground wire before connecting it to the ground terminal of your amplifier. In addition, Aunex recommends using high quality 100% OFC (Oxygen Free Cooper) or Tinned 100% OFC speaker wire. This will ensure that your speaker / subwoofer receives maximum output from your amplifier.

## Common Installation Diagrams

The illustrations below show the common installation methods for your amplifier. **(It is important to make sure that the impedance of your subwoofers are either 1 ohm or higher on the AC1000.1D and AC1500.1D. For the AC500.1D the subwoofer impedance should be 2 ohms or higher).** Connecting your amplifier below these impedances are not recommended as they will cause your amplifier to go into protection. If you are unsure of the impedance, it is recommended that use a DMM (Digital Multi-Meter) to check the impedance of your connection at the amplifiers' Speaker Output Terminals. Your amplifier will need to be off in order to get accurate measurements.

### AC500.1D

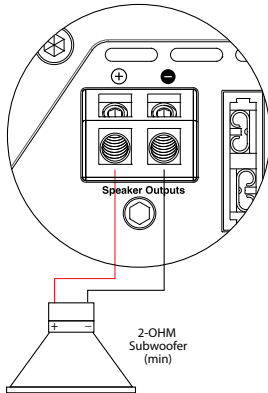

1. A Single Voice Coil Subwoofer Speaker

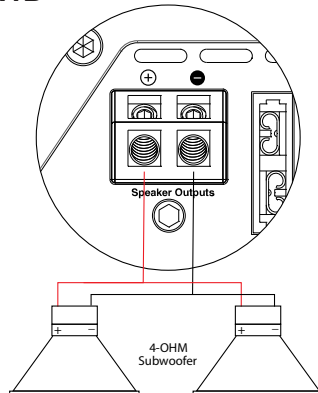

2. Two Single Voice Coil Subwoofer Speakers  
(Note: Don't connect speaker impedance under 2 ohms)

### AC1000.1D & AC1500.1D

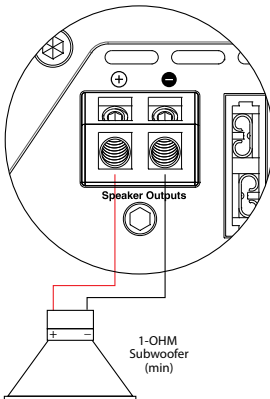

1. A Single Voice Coil Subwoofer Speaker

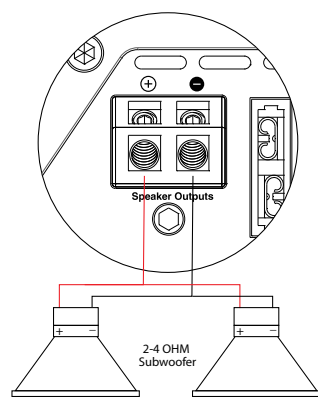

2. Two Single Voice Coil Subwoofer Speakers  
(Note: Don't connect speaker impedance under 1 ohm)



Note: One of the leading causes of amplifier failure is using inferior Power, Ground and Speaker wires that are not sufficient in quality to deliver the necessary current to keep your amplifier performing at its peak level. As all Aunex amplifiers are designed to deliver high power output, we recommend that you do not use any power wires that contains CCA (Copper Clad Aluminum). Instead we recommend only using high quality 100% OFC (Oxygen Free Copper) or 100% Tinned OFC (Oxygen Free Copper) wires. This will help give your amplifier the proper current and will ensure that your amplifier will perform at this peak perform level for many years to come.



Ask your Authorized Aunex Dealer or visit [www.aunexusa.com](http://www.aunexusa.com) to view the complete line of installation accessory that will compliment your audio investment. Aunex provides a wide election from RCA cables and power wire to speaker wire and battery connectors.



## Technical Specifications

Specifications	AC500.1D
Channels	1
Rated RMS Power 4 Ohms Mono @ 14.4 Volts	350 Watts x 1
Rated RMS Power 2 Ohms Mono @ 14.4 Volts	500 Watts x 1
Peak Music Power	1000 Watts
Frequency Response	10Hz – 250Hz
THD + Noise	< 1.0%
S/N Ratio A-Weighted	> 106dB
Input Sensitivity (Auto Detect High / Low Level)	250mV – 10V
Crossover Low Pass (24dB/Octave)	50Hz – 250Hz
Boost EQ Low Pass - 45Hz Centered	0 – 18dB
Infrasonic Filter	10Hz - 50Hz
Efficiency @ 4 Ohm	85%
Operating Voltage	9 – 17 Volts
Fuse Requirement	60A (Included)
Dimensions (H x W x D) Inches	2.0 x 7.8 x 6.2
Dimensions (H x W x D) MM	52 x 198 x 157

Specifications	AC1000.1D	AC1500.1D
Channels	1	1
Rated RMS Power 4 Ohms Mono @ 14.4 Volts	400 Watts x 1	700 Watts x 1
Rated RMS Power 2 Ohms Mono @ 14.4 Volts	700 Watts x 1	1100 Watts x 1
Rated RMS Power 1 Ohm Mono @ 14.4 Volts	1000 Watts x 1	1500 Watts x 1
Peak Music Power	2000 Watts	3000 Watts
Frequency Response	10Hz – 250Hz	10Hz – 250Hz
THD + Noise	< 1.0%	< 1.0%
S/N Ratio A-Weighted	> 105dB	> 105dB
Input Sensitivity (Auto Detect High / Low Level)	250mV – 10V	250mV – 10V
Crossover Low Pass (24dB/Octave)	50Hz – 250Hz	50Hz – 250Hz
Boost EQ Low Pass - 45Hz Centered	0 – 18dB	0 – 18dB
Infrasonic Filter	10Hz - 50Hz	10Hz - 50Hz
Efficiency @ 4 Ohm	86%	84%
Operating Voltage	9 – 17 Volts	9 – 17 Volts
Fuse Requirement	90A (Included)	200A (Included)
Dimensions (H x W x D) Inches	2.0 x 9.4 x 6.2	2.0 x 15.3 x 6.2
Dimensions (H x W x D) MM	52 x 238 x 157	52 x 338 x 157

**\*Due to continuous product improvements; specifications and features are subject to change without notice. Please visit [www.aunexusa.com](http://www.aunexusa.com) for the most current information.**

**\*This manual is the exclusive property of Aunex, Inc. Any reproduction of this manual or use other than its intended purposes is strictly prohibited without the express written consent of Aunex, Inc. ©Copyright 2020 Aunex, Inc.**

## Troubleshooting

Problem	Solution
Amplifier does not work; no LED's on	<ol style="list-style-type: none"> <li>1. Check to see if Power, Remote and Ground is connected to the Amplifier.</li> <li>2. Check Power and Remote Turn-on lead for proper +12 Voltage. (12 - 16 Volts DC acceptable range.)</li> <li>3. Check the inline fuse, replace if necessary.</li> </ol>
Amplifier powers up; no sound	<ol style="list-style-type: none"> <li>1. Check your RCA connectors to see if there is signal with a DMM (Digital Multi-Meter) to measure AC voltage.</li> <li>2. Check your speakers to see if there is short.</li> </ol>
Hissing / Enginer noise from speakers	<ol style="list-style-type: none"> <li>1. Readjust your amplifiers gains to lower setting.</li> <li>2. Readjust your source unit volume.</li> <li>3. Make sure your RCA's and Speaker wires are routed away from your Power and Ground connections.</li> <li>4. Remove existing ground wires for all electrical components. Reground wires to a different location. Verify the grounding location is clean, paint from ground point has been removed and is rust free.</li> <li>5. Add a secondary ground cable from the negative battery terminal to the chassis metal or engine block of vehicle.</li> <li>6. Check your RCA cables or speaker input for any damage.</li> </ol>
Distorted sound from speakers	<ol style="list-style-type: none"> <li>1. Readjust your amplifiers gains to a lower setting.</li> <li>2. Readjust your source unit volume.</li> <li>3. Readjust the Boost Eq.</li> </ol>
Logo Status LED is Red / Protection Circuit Active	<ol style="list-style-type: none"> <li>1. Amplifier may be in thermal protection due to heat.</li> <li>2. Check the inline fuse, replace if necessary.</li> <li>3. Check the voltage at the amplifier power input terminals.</li> </ol>

## California Prop 65 Warning

California's Proposition 65 (Prop 65) entitles consumers in California to special warnings for products that contain chemicals known to the state of California to cause cancer, birth defects or other reproductive harm if consumers are exposed to such chemicals above certain threshold levels.

While this law is only for California and Aunex sells products to consumers in California, Aunex is required to display this warning.



Warning: This product can expose you to chemicals which are known to the State of California to cause cancer or birth defects or other reproductive harm. For more information visit [www.p65warnings.ca.gov](http://www.p65warnings.ca.gov).

## Warranty

### Limited Warranty – AC Series Amplifiers

Aunex, Inc. warrants this product to be free of defects in materials and workmanship for a period of 1 year from the original purchase date. This warranty is non-transferrable and applies only to the original purchaser from an Authorized Aunex Dealer. **(Any Factory Refurbished Amplifier (B-Stock Products) carries a 90 Day warranty period.)** Should service be necessary within the warranty period, Aunex will at its discretion repair or replace the defective unit with a new or remanufactured product at no charge. Damage caused by misuse, abuse, accidental damage, product modification, failure to follow installation instructions, unauthorized repairs will not be covered under warranty. This warranty does not cover incidental or consequential damages and does not cover the cost of having the unit removed or reinstalled. Cosmetic damages by accident or normal wear and tear are not covered under warranty. Subsequent damage to a other component will not be covered.



## Warranty Continued

Warranty will be voided if the product's serial number has been removed or defaced. Any applicable implied warranties are limited in duration to a period of the express warranty as provided in this manual beginning with the date of the original purchase and no warranties whether express or implied shall apply to this product thereafter. Some states do not allow limitation on implied warranties; therefore, these exclusions may not apply to you. This warranty gives you specific legal rights; however, you may have other rights that vary from state to state.

All warranty returns should be sent to Aunex freight prepaid and must be accompanied by proof of purchase; a copy of the purchase sales receipt. All returns whether sent by the Dealer of purchase or directly from the consumers must have a valid RMA number (Return Merchandise Authorization). Returns without a valid RMA number will be refused. The RMA number must be clearly written on the outside of your return package. Non-defective units will be returned to sender freight collect. Customers are responsible for shipping charges and insurance in sending products back to Aunex. Freight damage on returns is not covered under warranty so be sure to package your return in the original box or packaged securely in another box to prevent possible freight damage. Warranty expiration on items without proof of purchase will be determined from the manufacturing date code.

Products purchased outside of the United States of America are covered by that country's distributor and not by Aunex, Inc. For Service Information in the U.S.A. and to obtain a Return Merchandise Authorization number (RMA) please call Aunex at (909) 589-5010.

# AUNEX

AUDIO FOR THE **NEXT** GENERATION



**Declare Your Independence!**

Aunex, Inc.  
13865 Magnolia Avenue, Unit C  
Chino, CA 91710  
T. (909) 589-5010 / F. (909) 589-5011  
8:30am – 5:30pm (PST – Pacific Standard Time)  
[www.aunexusa.com](http://www.aunexusa.com)